

HAGBARD

Heavy duty fast changing smart pushing block

EXTRUSION TOOLING



 UDDEHOLM

MACHINING AB

WWW.UDDEHOLM-MACHINING.COM

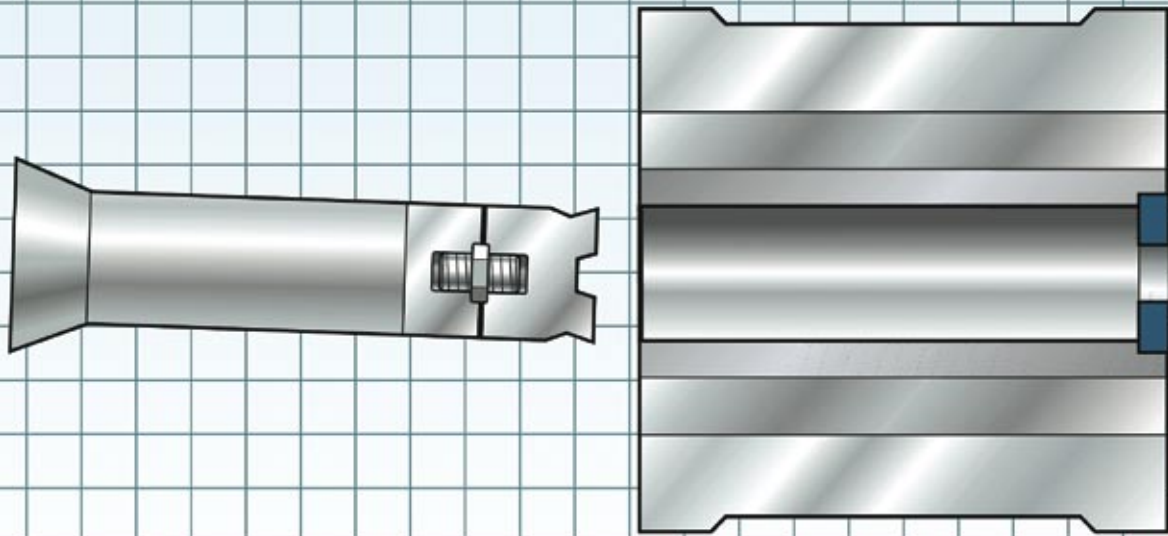

THE PROBLEM

Dummy Blocks Are Working Hard

They are subjected to heat, pressure, temperature changes and mechanical stresses.

- Wear on sealing surfaces
- Growth of dimension
- Loss of flexibility
- Misalignment, uneven wear

It is no wonder that dummy blocks wear.
The problem is that they wear too fast.

Dummy block wear increases cost in several ways:

- Cost for the dummy blocks themselves
- Cost for change in terms of loss of production time and manpower

Additionally, production stops influence other parts and plant performance.
All these drawbacks are leading to higher production costs!



Patent Nr. 521971

THE SOLUTION

We Invented Hagbard

The most convenient way to overcome the drawbacks of dummy block wear is to use HAGBARD from Uddeholm Machining.

HAGBARD is the result of cooperation between Uddeholm Machining and Uddeholm Tooling. The HAGBARD active pushing block combines the superb performance of DIEVAR hot work steel with an ingenious design.

DIEVAR is a hot work, consistent performance, wear resistant, ductile, shape stable material.

DESIGN of the block is based on long experience from cooperation with many extrusion plants, technical know-how and elaborate calculations. The design not only enables rapid change – it also ensures long trouble-free operation.

HAGBARD comprises of few parts which makes it easy to handle and to service.

The next step is just to start making money!



THE RESULTS

Case: Profilgruppen Sweden

1. BASIC DATA		3. PRESENT	
Type of press	Conventional	Type of dummy block	HAGBARD
Dimensions (inches)	8	Life (billets/block)	40000 (20000+20000)
Force (tons)	2200	Service	After 20000 billets: turning approx 0,2 mm then another 20000 billets before out of service
Pressure (N/mm ²)	54-56		
Alloy types	6000		
Greasing	Boron Nitride		
Production	3 shifts/day		
2. BEFORE		4. DIFFERENCE	
Type of dummy block	Conventional	Life cycle factor	2,6-3,6
Material	Dievar	Comments	"Simpler and faster"
Life (billets/block)	11000-15000	Time (service/change)	Faster
Service			
Comments	"Relatively good for a conventional block"		



UDDEHOLM MACHINING

A Company In The Uddeholm Group

Our job is to create even more customer value out of Uddeholm Tool Steel by bringing it into ready-to-use components or systems.

We want to be your partner in the never ending strives for highest performance and lowest cost per produced unit.

Uddeholm Machining has been working together with extrusion plants for more than 20 years. During those years we have seen many problems and success stories and have definitely learned a lot. High quality and creative solutions stem out of the combination of our experience and the highly qualified researchers at Uddeholm Tooling. Together we find the causes of any issue and advise you to appropriate countermeasures.

In addition to advise, we also provide drawings, engineering support and components or systems.

We are relining and refurbishing containers for our customers regularly as a part of our long lasting commitment.

UDDEHOLM EUROPE

AUSTRIA

UDDEHOLM
Hansaallee 321
D-40549 Düsseldorf
Telephone: +49 211 535 10
Telefax: +49 211 535 12 80

BELGIUM

UDDEHOLM N.V.
Waterstraat 4
B-9160 Lokeren
Telephone: +32 9 349 11 00
Telefax: +32 9 349 11 11

CZECHIA

UDDEHOLM PRAHA GmbH
Ruzyně Vytvarná 12/2
S R O 16100 Praha 6
Telephone: +420 2 301 6519
Telefax: +420 2 301 5877

DENMARK

UDDEHOLM A/S
Kokmose 8, Bramdrupdam
DK-6000 Kolding
Telephone: +45 75 51 70 66
Telefax: +45 75 51 70 44

ESTONIA

UDDEHOLM TOOLING AB
Silikatsiidi 7
EE-0012 Tallinn
Telephone: +372 655 9180
Telefax: +372 655 9181

FINLAND

OY UDDEHOLM AB
Ritakuja 1, PL 57,
FIN-01741 VANTAA
Telephone: +358 9 290 490
Telefax: +358 9 2904 9249

FRANCE

UDDEHOLM S.A.
12 Rue Mercier, Z.I. de Mitry-Compans
F-77297 Mitry Mory Cedex
Telephone: +33 (0)1 60 93 80 10
Telefax: +33 (0)1 60 93 80 01

Branch office

UDDEHOLM S.A.
77bis, rue de Vesoul
La Nef aux Métiers
F-25000 Besançon
Telephone: +33 381 53 12 19
Telefax: +33 381 53 13 20

GERMANY

UDDEHOLM
Hansaallee 321
D-40549 Düsseldorf
Telephone: +49 211 535 10
Telefax: +49 211 535 12 80

Branch offices

UDDEHOLM
Falkenstraße 21
D-65812 Bad Soden/TS.
Telephone: +49 6196 659 60
Telefax: +49 6196 659 625

UDDEHOLM

Albstraße 10
D-73765 Neuhausen
Telefon: +49 715 898 65-0
Telefax: +49 715 898 65-25

GREAT BRITAIN, IRELAND

UDDEHOLM UK LIMITED
European Business Park
Taylors Lane, Oldbury
West Midlands B69 2BN
Telephone: +44 121 552 55 11
Telefax: +44 121 544 29 11
Dublin Telephone: +353 1 45 14 01

GREECE

UDDEHOLM STEEL TRADING
COMPANY
20, Athinon Street
G-Piraeus 18540
Telephone: +30 2 10 41 72 109/41 29
820

Telefax: +30 2 10 41 72 767

SKLERO S.A.
Steel Trading Comp. and
Hardening Shop
Frixou 11/Nikif. Ouranou
G-54627 Thessaloniki
Telephone: +30 31 51 46 77
Telefax: +30 31 54 12 50

HUNGARY

UDDEHOLM TOOLING/BOK
Dunaharaszti, Jedlik Ányos út 25
H-2331 Dunaharaszti 1.Pf. 110
Telephone/Telefax: +36 24 492 690

ITALY

UDDEHOLM Italia S.p.A.
Via Palizzi, 90
I-20157 Milano
Telephone: +39 02 35 79 41
Telefax: +39 02 390 024 82

LATVIA

UDDEHOLM TOOLING AB
Deglava street 50
LV-1035 Riga
Telephone: +371 7 701 983, -981, -982
Telefax: +371 7 701 984

LITHUANIA

UDDEHOLM TOOLING AB
BE PLIENAS IR METALAI
T. Masiulio 18b
LT-3014 Kaunas
Telephone: +370 37 370613, -669
Telefax: +370 37 370300

THE NETHERLANDS

UDDEHOLM B.V.
Isolatorweg 30
NL-1014 AS Amsterdam
Telephone: +31 20 581 71 11
Telefax: +31 20 684 86 13

NORWAY

UDDEHOLM A/S
Jernkroken 18
Postboks 85, Kalbakken
N-0902 Oslo
Telephone: +47 22 91 80 00
Telefax: +47 22 91 80 01

POLAND

INTER STAL CENTRUM
Sp. z.o.o./Co. Ltd.
Dzieskanow Polski, ul. Kolejowa 291,
PL-05-092 Lomianki
Telephone: +48 22 751 5675
Telefax: +48 22 751 5670

PORTUGAL

F RAMADA Aços e Industrias S.A.
P.O. Box 10
P-3881 Ovar Codex
Telephone: +351 56 58 61 11
Telefax: +351 56 58 60 24

RUSSIA

UDDEHOLM TOOLING CIS
25 A Bolshoy pr PS
197198 St. Petersburg
Telephone: +7 812 233 9683
Telefax: +7 812 232 4679

SLOVAKIA

UDDEHOLM Slovakia
Nástrojové ocele, s.r.o
KRÁCINY 2
036 01 Martin
Telephone: +421 842 4 300 823
Telefax: +421 842 4 224 028

SLOVENIA

UDDEHOLM Italia S.p.A.
Via Palizzi, 90
I-20157 Milano
Telephone: +39 02 35 79 41
Telefax: +39 02 390 024 82

SPAIN

UDDEHOLM
Guifré 690-692
E-08918 Badalona, Barcelona
Telephone: +34 93 460 1227
Telefax: +34 93 460 0558

Branch office

UDDEHOLM
Barrio San Martin de Arteaga, 132
Pol.Ind. Torrelarragoiti
E-48170 Zamudio
(Bizkaia)
Telephone: +34 94 452 13 03
Telefax: +34 94 452 13 58

SWEDEN

UDDEHOLM TOOLING
SVENSKA AB
Aminogatan 25
SE-431 53 Mölndal
Telephone: +46 31 67 98 50
Telefax: +46 31 27 02 94

SWITZERLAND

HERTSCH & CIE AG
General Wille Strasse 19
CH-8027 Zürich
Telephone: +41 1 208 16 66
Telefax: +41 1 201 46 15
HANS KOHLER AG
Claridenstrasse 20
CH-8002 Zürich
Telephone: +41 1 207 11 11
Telefax: +41 1 207 11 10

UDDEHOLM

NORTH AMERICA

USA

UDDEHOLM
4902 Tollview Drive
Rolling Meadows IL 60008
Telephone: +1 847 577 22 20
Telefax: +1 847 577 80 28

UDDEHOLM

548 Clayton Ct.,
Wood Dale IL 60191
Telephone: +1 630 350 10 00
Telefax: +1 630 350 08 80

UDDEHOLM

9331 Santa Fe Springs Road
Santa Fe Springs, CA 90670
Telephone: +1 562 946 65 03
Telefax: +1 562 946 77 21

UDDEHOLM

7900 Hub Parkway
Cleveland OH 44125
Telephone: +1 216 524 87 70
Telefax: +1 216 642 10 42

CANADA

UDDEHOLM LIMITED
2595 Meadowvale Blvd.
Mississauga, Ontario L5N 7Y3
Telephone: 905 812 9440
Telefax: 905 812 8659

MEXICO

UDDEHOLM
Calle Ocho no 2, Letra "C"
Fracc. Industrial Alce Blanco
53370 Naucalpan de Juarez
Estado de Mexico
Telephone: +52 5-576 5422
Telefax: +52 5-576 2139

UDDEHOLM

Lerdo de Tejada No.542
Colonia Las Villas
66420 San Nicolas de Los Garza, N.L.
Telephone: +52 8-352 5239
Telefax: +52 8-352 5356

UDDEHOLM

SOUTH AMERICA

ARGENTINA

UDDEHOLM S.A.
Mozart 40
1619-Centro Industrial Garin
Garin-Prov. Buenos Aires
Telephone: +54 332 744 4440
Telefax: +54 332 745 3222

BRAZIL

UDDEHOLM ACOS ESPECIAIS Ltda.
Estrada Yae Massumoto, 353
CEP 09842-160
Sao Bernardo do Campo - SP Brazil
Telephone: +55 11 4393 4560, -4554
Telefax: +55 11 4393 4561

UDDEHOLM

SOUTH AFRICA

UDDEHOLM Africa (Pty) Ltd.
P.O. Box 539
ZA-1600 Isando/Johannesburg
Telephone: +27 11-974 2781
Telefax: +27 11-392 2486

UDDEHOLM

AUSTRALIA

BOHLER-UDDEHOLM Australia
129-135 McCredie Road
Guildford NSW 2161
Private Bag 14
Telephone: +61 2 9681 3100
Telefax: +61 2 9632 6161

Branch offices

Sydney, Melbourne, Adelaide,
Brisbane, Perth, Newcastle,
Launceston, Albury, Townsville

ASSAB

ASSAB INTERNATIONAL

Skytteholmsvägen 2
P O Box 42
SE-171 11 Solna
Sweden
Telephone: +46 8 564 616 70
Telefax: +46 8 25 02 37

Subsidiaries

India, Iran, Turkey, United Arab Emirates
Distributors in
Africa, Latin America, Middle East

ASSAB PACIFIC

ASSAB Pacific Pte. Ltd
171, Chin Swee Road
No. 07-02, San Centre
Singapore 169877
Telephone: +65 534 56 00
Telefax: +65 534 06 55

Subsidiaries

China, Hong Kong, Indonesia, Japan,
Korea, Malaysia, Philippine Islands,
Singapore, Taiwan, Thailand

When the first idea pops into your head, throughout the development process to the release of the new product, we'll be your partner. As the world's leading supplier of tooling materials and related services, we can be trusted. Meet us under the Uddeholm and ASSAB brands, wherever in the world you have your business.



MACHINING AB